



ARIANE 6

LOWA Rods Test Load Introduction System Specification for Manufacturing

The technical specification for the required welded structure.

Doc No.: A6-TS-1530100-X-005-VZL
Issue 1.1

Internal No.: n/a

Intellectual Property Note:

This document or any part of its content may not be reproduced or disclosed to third parties without prior permission of Czech Aerospace Research Centre

©VZLU



Doc.No: **A6-TS-1530100-X-005-VZL**

Issue: **1.1** Date: **3.12.2020**

Page: **2** of **20**

LOWA Rods Test Load Introduction System

CHANGE RECORDS:

Rev. #	Sheet	Description	Date	Approved
1.0	All	Initial Issue	23.11.2020	Franc
1.1	All	Added LOWA Rods	3.12.2020	Franc



Doc.No: A6-TS-1530100-X-005-VZL

Issue: 1.1 Date: 3.12.2020

Page: 3 of 20

LOWA Rods Test Load Introduction System

CONTENTS:

ABBREVIATIONS:.....	4
1. INTRODUCTION	5
2. BASIC PARAMETERS	9
3. LOADING SCENARIOS	9
4. STRENGTH REQUIREMENTS.....	11
5. INTERFACE REQUIREMENTS	12
6. WELDING REQUIREMENTS	15
7. FASTENERS AND PINS	15
8. GENERAL REQUIREMENTS	16
9. SCHEDULE / MILESTONES	17
10. DELIVERABLES	17



Doc.No: **A6-TS-1530100-X-005-VZL**

Issue: **1.1** Date: **3.12.2020**

Page: **4** of **20**

LOWA Rods Test Load Introduction System

ABBREVIATIONS:

BC – Boundary Condition

CAD – Computer-Aided Design

DLL – Design Limit Load

DOF – Degrees of Freedom

ERES – Equipped SRM Rear Skirt

LC – Lower Cover – SRM

LOWA – Lower Attachment

MAPS - Mechanical Anti-Pitching System

SRM – Solid Rocket Motor

UC – Upper Cover - Pallet

VZLU – Czech Aerospace Research Centre



Doc.No: **A6-TS-1530100-X-005-VZL**

Issue: **1.1** Date: **3.12.2020**

Page: **5** of **20**

LOWA Rods Test Load Introduction System

1. INTRODUCTION

VZLU is participating in the development of the new European heavy launcher ARIANE 6.

One of the activities provided is the Qualification testing of the SRM Rear Skirt – part on which the whole launcher stands when placed on the launch pad.



Figure 1: Position of the ESR Rear Skirt

For this Qualification test, the VZLU is preparing the Test Rig which must be able to withstand the load, representing the situation on the launch pad of about 700 tons (among other specific loads). The tendered structure – LOWA Rods Test Load Introduction System is the part of this Test Rig.

LOWA Rods Test Load Introduction System

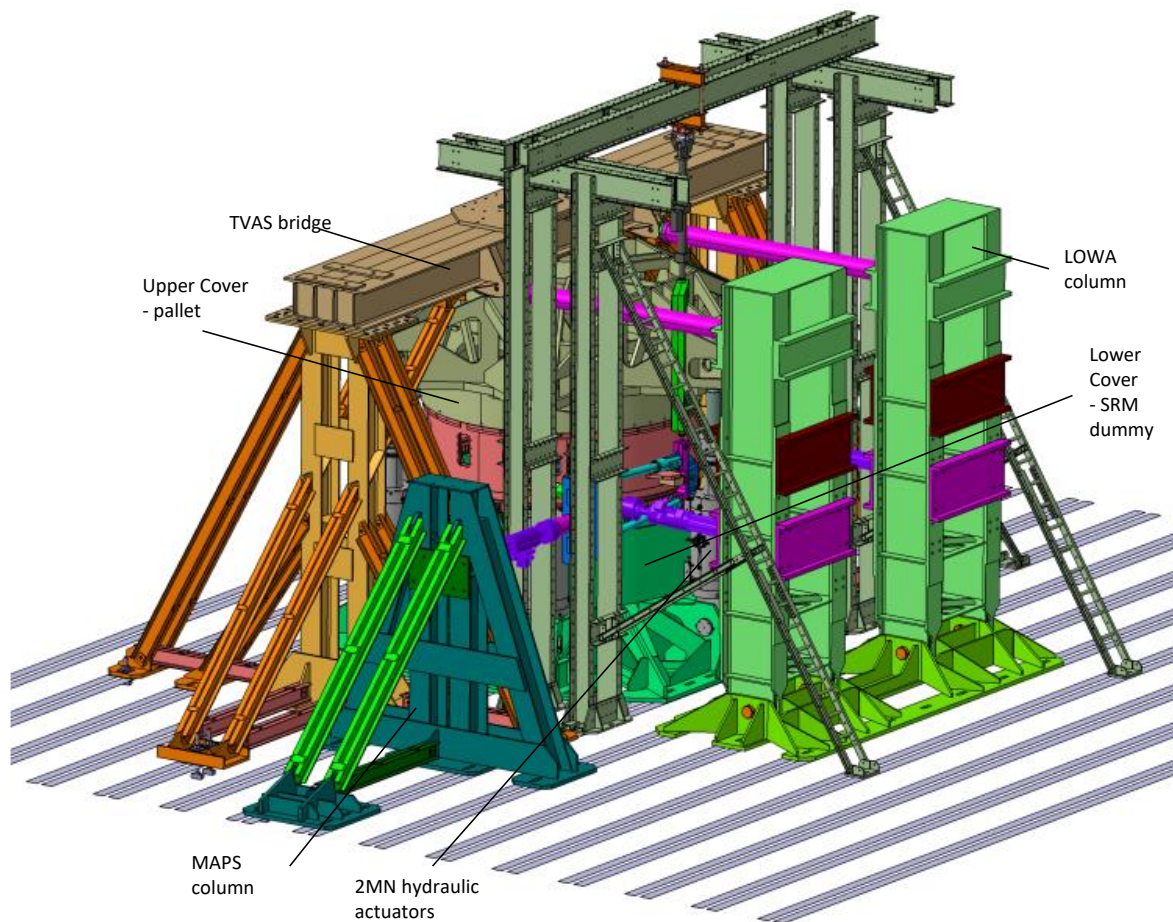

Figure 2: ESR Rear Skirt Test Rig Setup in Ground Configuration

The Test Rig in ground configuration consists of:

- Upper Cover – pallet
- Lower Cover – SRM
- TVAS Bridge
- LOWA Rods Test Load Introduction System
- MAPS Test Load Introduction System
- Hydraulic actuators.

The test specimen is mounted by bolts to the Lower Cover – SRM which simulates the main body of the launcher booster. The Upper Cover – pallet is placed on top of the Test Specimen and is interconnected with the Lower Cover – SRM by six hydraulic actuators. The Lower Cover – SRM is connected to the rails of test hall floor by T-bolts. This assembly will load the Test Specimen during the test in compression.

LOWA Rods Test Load Introduction System

The LOWA Rods Test Load Introduction System is the object of the tender.

It consists of several parts as shown in Figure 3:

- Columns (2 pieces)
- Actuator's attachment plates (10 pieces)
Note: As rear plate in the assembly the front plate from another loading scenario is used
- Bottom part (1 piece)
- Connecting rods (2 pieces)

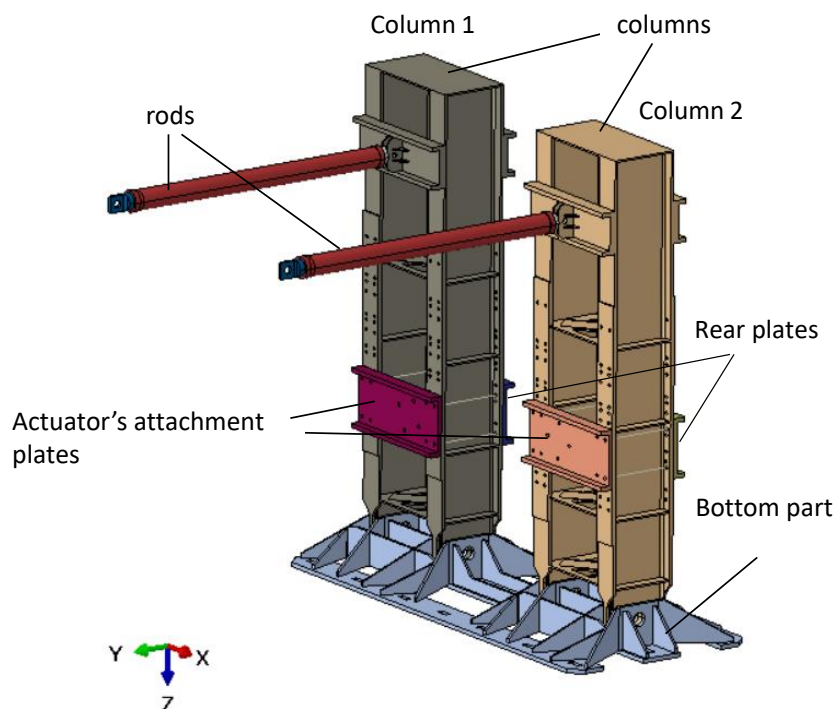

Figure 3: LOWA Rods test load introduction system

Individual parts are connected together by pins and the whole structure is tightened to the ground by T-bolts M52x3. Rods are connected to the TVAS bridge of the test rig in the upper part. Basic dimensions are shown in Figure 4.

Actuator's base plates are connected through eight stud bolts M36 going through columns vertical profiles and rear plates. Different actuator's plates are used according to the configuration (see Figure 5).



ARIANE 6

Doc.No: **A6-TS-1530100-X-005-VZL**

Issue: **1.1** Date: **3.12.2020**

Page: **8** of **20**

LOWA Rods Test Load Introduction System

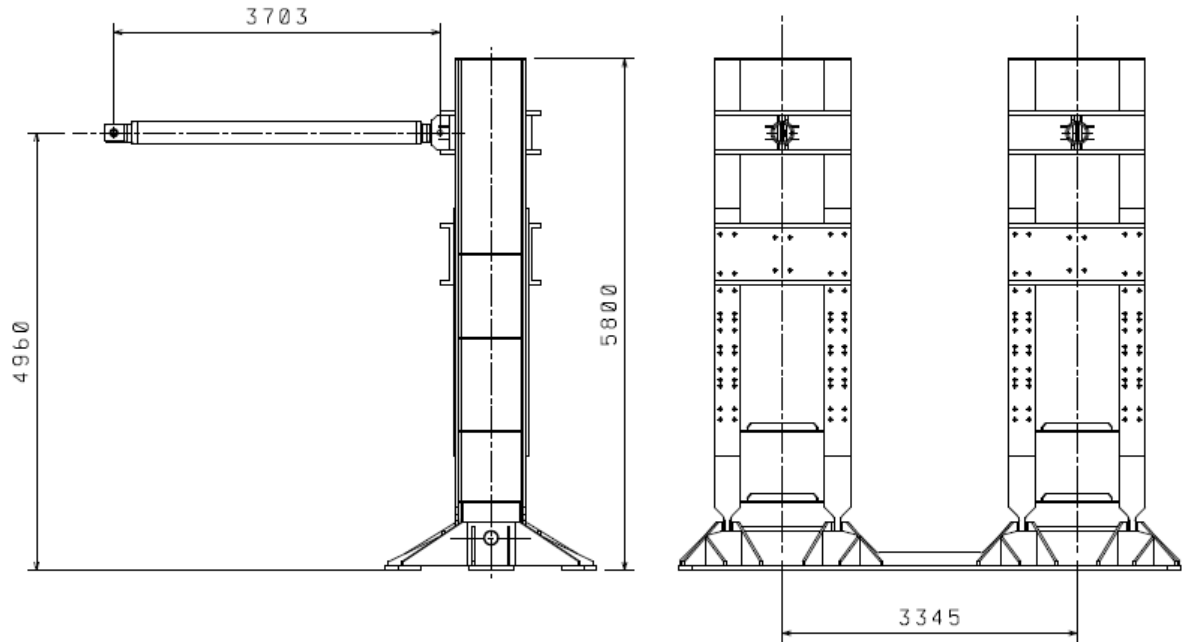

Figure 4: LOWA Rods test load introduction system – basic dimensions



LOWA Rods Test Load Introduction System

2. BASIC PARAMETERS

We require the manufacturing of the welded test rig structure of LOWA Rods test load introduction system according to the CAD model provided. The scope of the work contains:

- Establishing of the manufacturing drawings,
- performing analysis report (FEM recommended) based on VZLU specification,
- manufacturing of the structure and complete assembly at manufacturer side,
- measurements (geometry, tolerances, etc.),
- delivery to the VZLU premises.

The delivered structure must be manufactured to withstand the loading scenarios specified below in Chapter 3 and fulfill the requirements for the dimensions and tolerances of the interfaces specified in Chapter 5.

3. LOADING SCENARIOS

The LOWA Rods test load introduction system is designed to carry the load primarily in the horizontal direction. The vertical load components are also present since the inclination of the actuator's axis.

Nine configurations are expected during the test as shown in Figure 5. In some loading scenarios, side and vertical components of the loading vector are also present so that the columns are not loaded only in bending, but also in torsion. The vectors of actuator's axes are oriented regarding the used configuration as follows:

- The angulation of actuator's axes are 0 or 4 deg (in reference to the vertical plane).
- The inclination of actuator's axes are in the range from -10.7 up to 10.7 deg (in reference to the horizontal plane) on the column 1.
- The inclination of actuator's axes are in the range from -3.5 up to 3.5 deg (in reference to the horizontal plane) on the column 2.

All configurations are clear from Figure 5 and are included in the 3D model of the assembly.

The dimensioning load is specified as 2x Design Limit Load (DLL).

For dimensioning, two configurations 1 and 5 in "FLIGHT" scenario marked by red rectangles in Figure 5 can be used. The load in this scenario is specified as 720 kN for each actuator.

In the configuration 9, in "STIFFNESS" scenario the assembly is loaded by 540 kN in each actuator placed in the top position (marked by red dashed rectangle in Figure 5). This configuration shall be also used for dimensioning.

The dimensioning load is summarized in Table 3.

Force 2xDLL	Magnitude
„FLIGHT“ actuator's load at Column 1	720 kN
„FLIGHT“ actuator's load at Column 2	720 kN
„STIFFNESS“ actuator's load at Column 1	540 kN
„STIFFNESS“ actuator's load at Column 2	540 kN

Table 3: Dimensioning load specification



LOWA Rods Test Load Introduction System

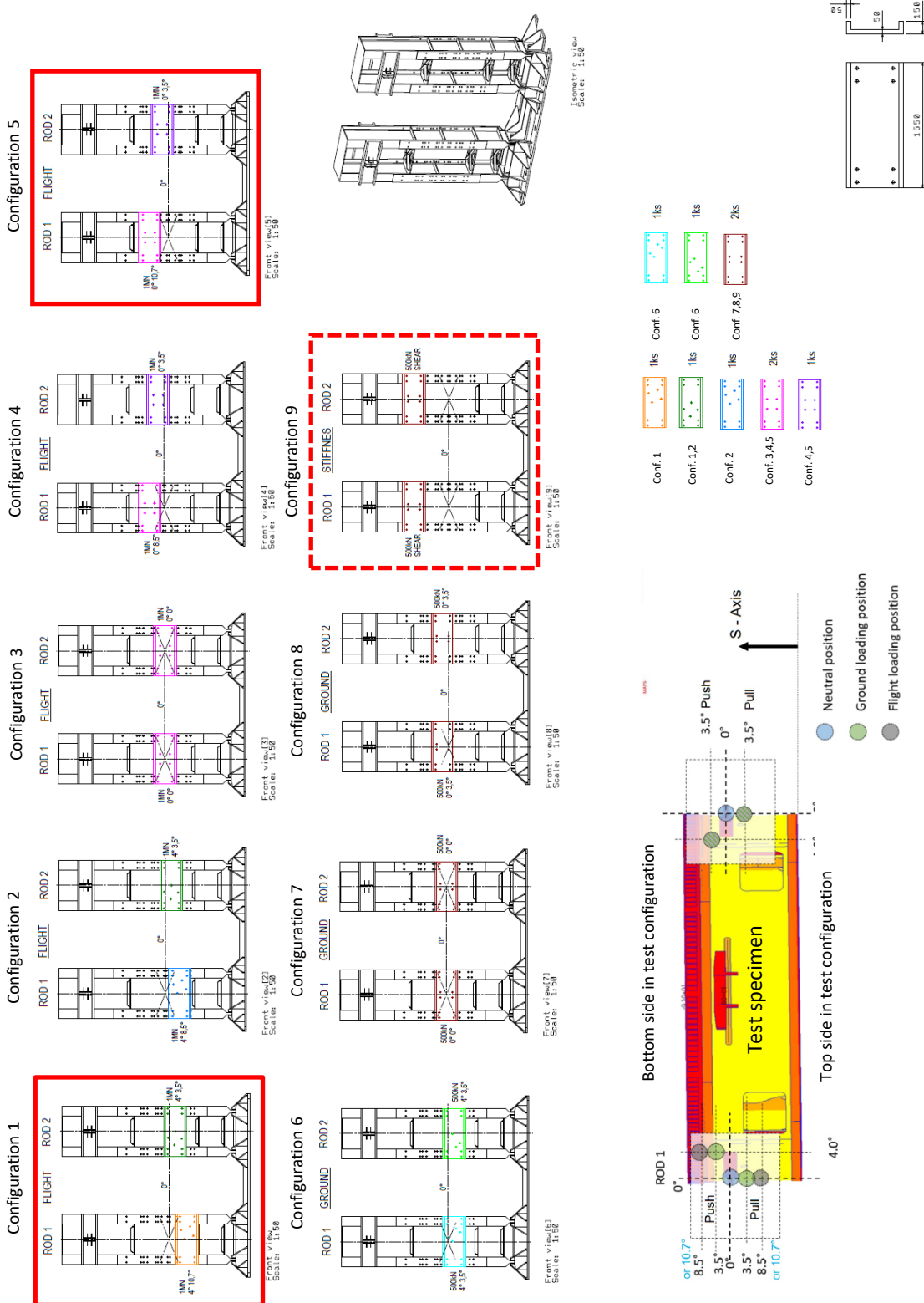

Figure 5: Loading configurations of actuator's plates; dimensioning config. shown in red square

LOWA Rods Test Load Introduction System

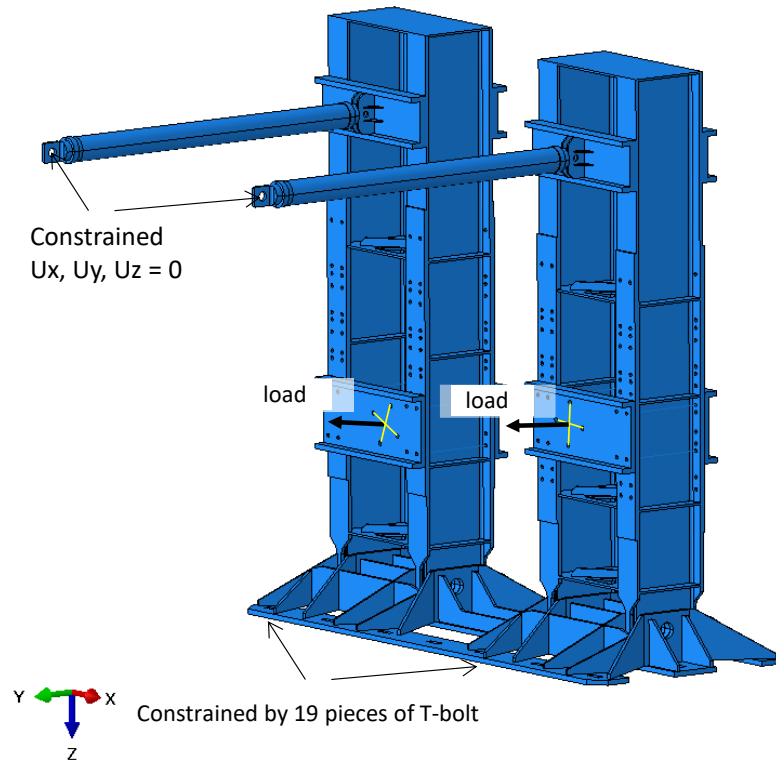

Figure 6: Assembly boundary conditions in "FLIGHT" configuration

4. STRENGTH REQUIREMENTS

The delivered structure must withstand the loads without loss of structural integrity. The safety factor against rupture (SF) should be minimally in the magnitude of two ($SF_{min.} = 2$) for all loading configurations for the whole structure.

Minimum material properties requirements:

a) For welded structure

- $E_{min} = 210$ GPa (steel S355JR)
- $R_{p0.2 min} = 315$ MPa
- $R_{m min} = 470$ MPa

b) For lugs

- $E_{min} = 210$ GPa
- $R_{p0.2 min} = 500$ MPa
- $R_{m min} = 650$ MPa

LOWA Rods Test Load Introduction System

5. INTERFACE REQUIREMENTS

For the successful performance of the test, the following elements of LOWA Rods test load introduction system are essential:

- a) Interfaces to the hydraulic actuators
- b) Interface to the rest of the test rig via connecting rods
- c) Interfaces to the test floor

a) Interface to the hydraulic actuators

These elements enable mounting of the hydraulic actuators and loading of the test specimen by the required load. Two types (optionally three types) of actuators will be used during the test. In “FLIGHT” load scenario, two pieces of 1MN actuators will be used (optionally one piece of 400kN actuator and one piece of 1MN). A hydraulic actuator will be mounted by four bolts M36 to the actuator’s plate. The hole pattern of the interface depends on the intended load configuration. The situation of used actuators is shown in Figure 5 and the hole pattern on actuator’s plates in Figure 7.

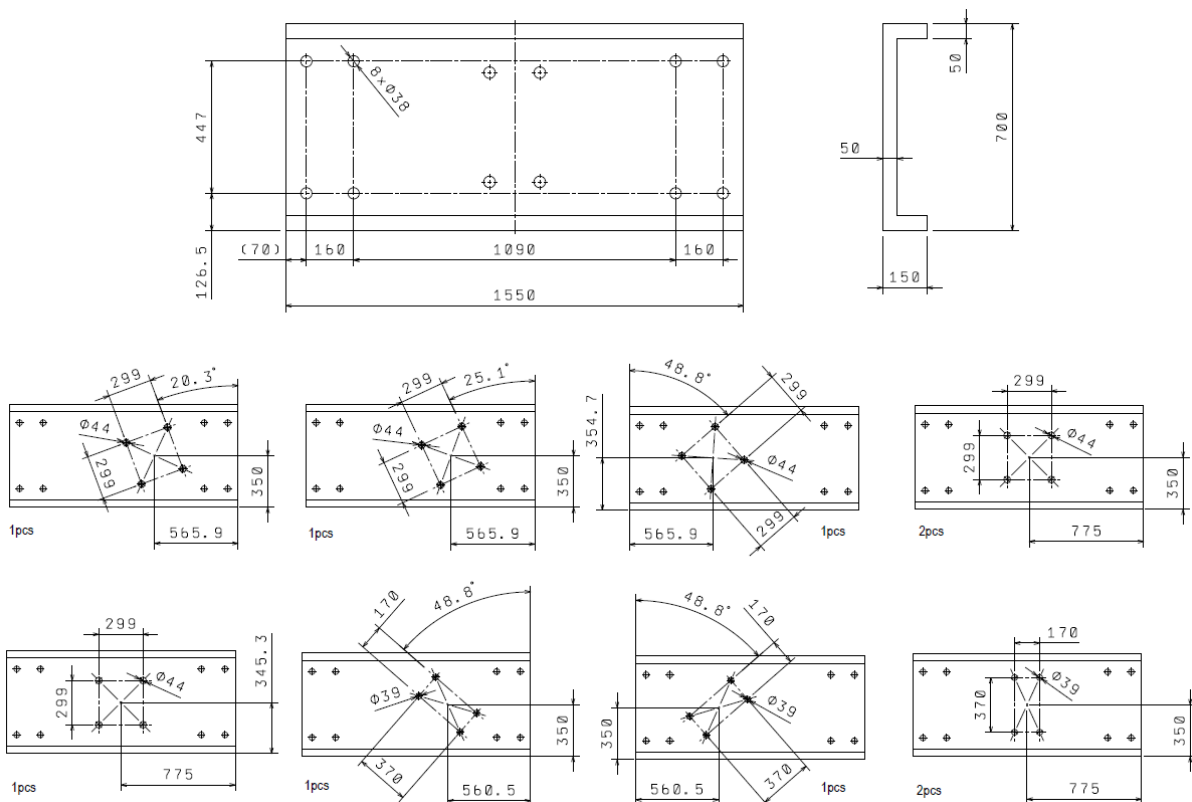

Figure 7: Actuator’s fitting – interface dimensions

The optional 400kN actuator’s fitting shall be manufactured together with the assembly. The dimensions are shown in Figure 8.



LOWA Rods Test Load Introduction System

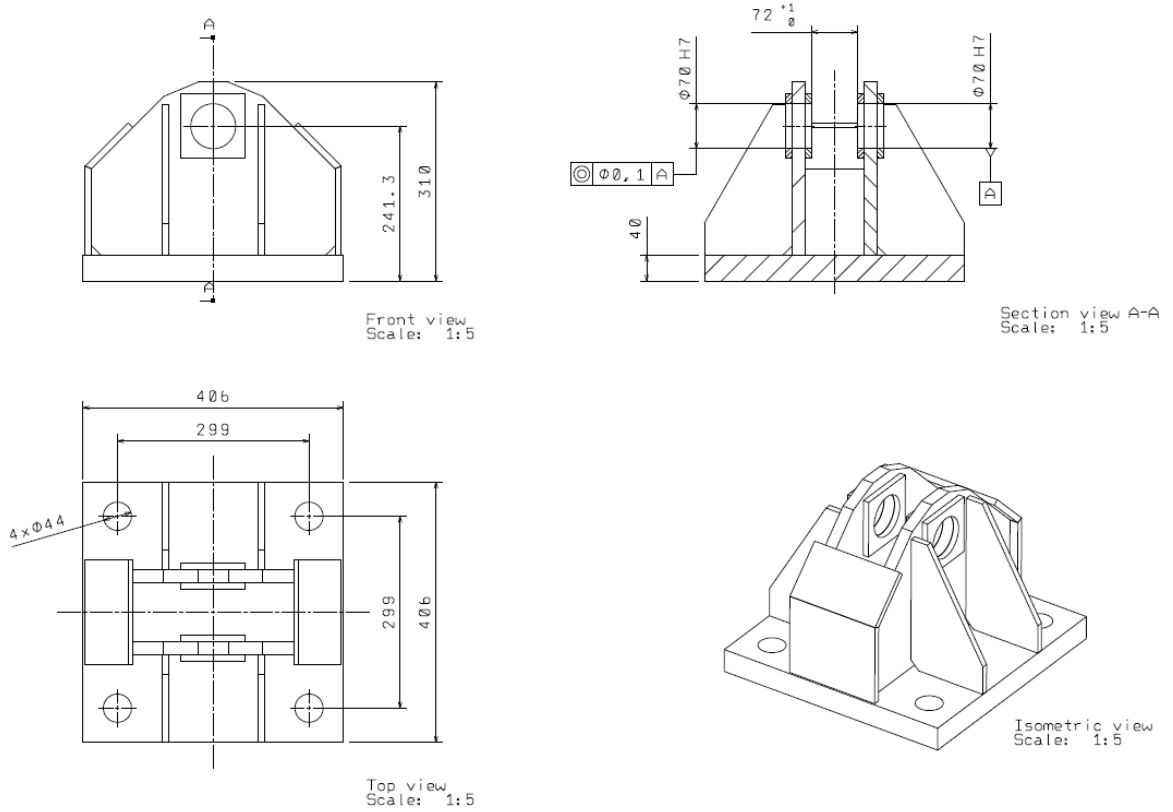

Figure 8: 400kN actuator's fitting

b) Interface to the rest of the test rig via connecting rods

The assembly is connected to the rest of the test rig (to the TVAS bridge) by connecting rods. The interface is designed as a lug for the connection by the pin with the diameter of 60 mm.

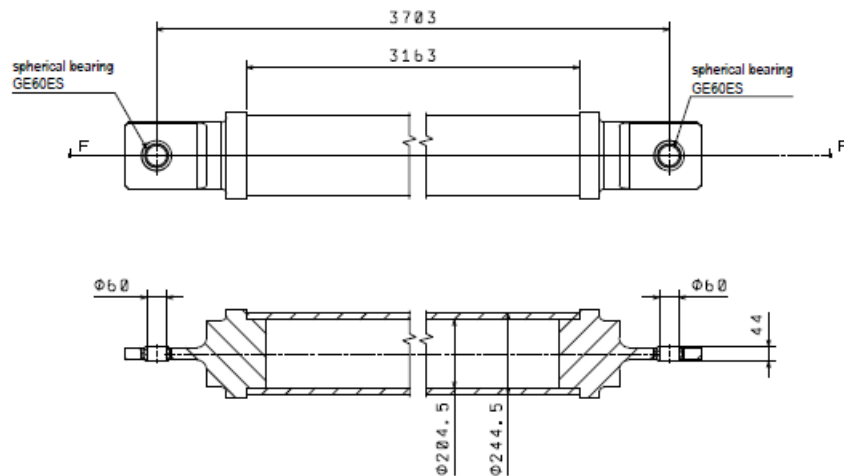

Figure 9: Connecting rods interface



Doc.No: **A6-TS-1530100-X-005-VZL**

Issue: **1.1** Date: **3.12.2020**

Page: **14** of **20**

LOWA Rods Test Load Introduction System

c) Interface to the test hall floor

Mounting of the LOWA Rods test load introduction system to the test hall floor and securing the test rig in required position is realized through this interface. The system is mounted by 19 pieces of T-bolts M52x3 mm. The holes for T-bolts in base plates have rectangular shape with dimensions of 210x60 mm. T-bolts are not included in the tender.

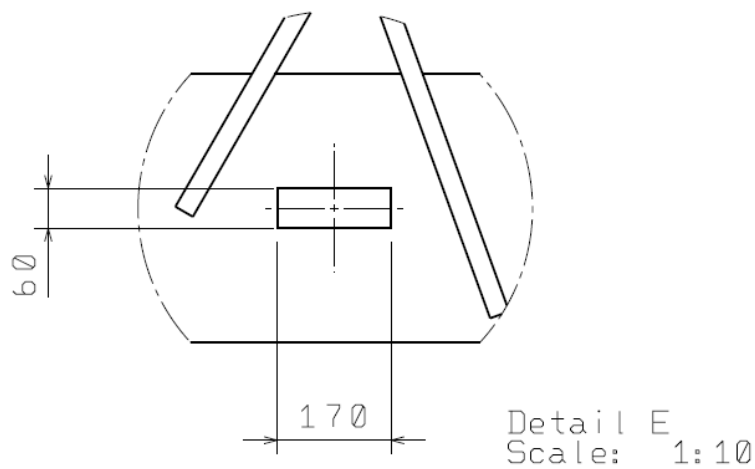
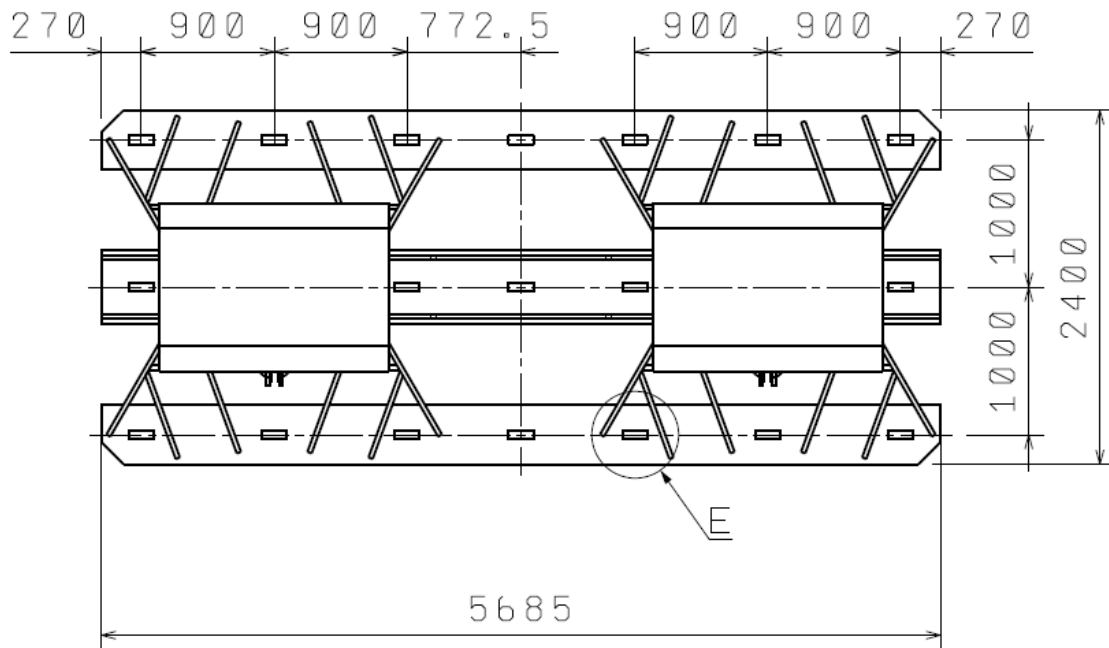

Figure 10: Interface to the test floor; top view



Doc.No: **A6-TS-1530100-X-005-VZL**

Issue: **1.1** Date: **3.12.2020**

Page: **15** of **20**

LOWA Rods Test Load Introduction System

6. WELDING REQUIREMENTS

General requirements

All welds shall be done that way that will fulfill requirements of EN ISO 5817 Quality level B. The Welding Procedure Specification (WPS) shall be prepared according to EN ISO 15607 and EN ISO 15614 prior to manufacturing.

All inspection protocols shall be provided as a part of the delivered documentation. The Inspection shall be done by an International Welding Inspector Level Comprehensive (IWI-C) according to International Authorization Board of International Institute of Welding.

7. FASTENERS AND PINS

For the assembly of individual components together the following fasteners pins and bearings shall be used. These components are included in the tender.

Fasteners

- Connection of the actuator's plates to the columns
16 pieces of stud bolt M36 10.9 or better (+ nuts and washers)
Clamping length 940 mm

Pins

- Connection of columns and bottom part
4 pieces of pin 160 8.8 or better (+washers and cotter pins)
Assembly length 182 mm
Note : Securing of the pin can be done by cotter pin or another standard way
- Connecting rods pin
4 pieces of pin 60 8.8 or better (+washers and cotter pins)
Note : Securing of the pin can be done by cotter pin or another standard way

Bearings

Bearings are used in following locations:

- In the lug of connecting rods
4 pieces of GE60ES



Doc.No: **A6-TS-1530100-X-005-VZL**

Issue: **1.1** Date: **3.12.2020**

Page: **16** of **20**

LOWA Rods Test Load Introduction System

8. GENERAL REQUIREMENTS

In addition to requirements stated above, following requirements shall be applied.

1. Body surface finish – Blue color (RAL 5015) paint with exception of the interface surfaces.
2. LOWA Rods column shall be equipped with lifting lugs for crane handling.
3. The system shall be assembled at the supplier premises prior to deliverable to ensure that all components fit together, than disassembled and delivered to VZLU.
4. The stress relief (annealing) after welding and before final machining shall be done.
5. The LOWA Rods test load introduction system shall be delivered with the following measurement protocols:
 - a) Overall dimensions and mass measurement protocol
 - b) Hydraulic actuators interface measurement protocol
 - c) Certificates of used materials
 - d) Welds inspection protocols
 - e) Certificates of the inspection personnel

**LOWA Rods Test Load Introduction System****9. SCHEDULE / MILESTONES**

The following Milestones are foreseen:

Milestone	Description	Date
Kick-off	Contract signature	T0
M1	Manufacturing readiness review	no later than T0 + 4 weeks
M2	Delivery review board*	no later than T0 + 17 weeks
M3	Takeover at VZLÚ	no later than T0 + 18 weeks

*The Delivery Review Board will take place at the supplier premises before the transport to VZLU.

The regular Progress meeting/telecon is required once per 4 weeks or acc. to VZLU requirements.

10. DELIVERABLES

Documentation:

- Activities time plan
- Manufacturing drawings – the whole set of drawings which allows the manufacturing.
- Welding Procedure Specification – Supplier shall prepare WPS in accordance the EN ISO 15607 and EN ISO 15614 for the whole structure prior manufacturing.
- System Analysis Report – Supplier shall prove in this document that the whole welded structure will fulfill the requirements. The analysis using finite element method is recommended.
- Measurement Plan – Supplier shall describe the measurement logic in this document (what and when will be measured) applied throughout the whole manufacturing process to achieve the required dimensions and tolerances.
- Measurement protocols – The measurement protocols as specified in Chapter 8.

The following deliverables are required:

Description	Milestone
Manufacturing drawing	M1
Welding Procedure Specification	
System Analysis Report	
Measurement Plan	
Measurement protocols	M2
LOWA Rods Test Load Introduction System (Hardware)	



ARIANE 6

Doc.No: A6-TS-1530100-X-005-VZL

Issue: 1.1 Date: 3.12.2020

Page: 18 of 20

LOWA Rods Test Load Introduction System

ANNEX 1 – Overall Dimensions

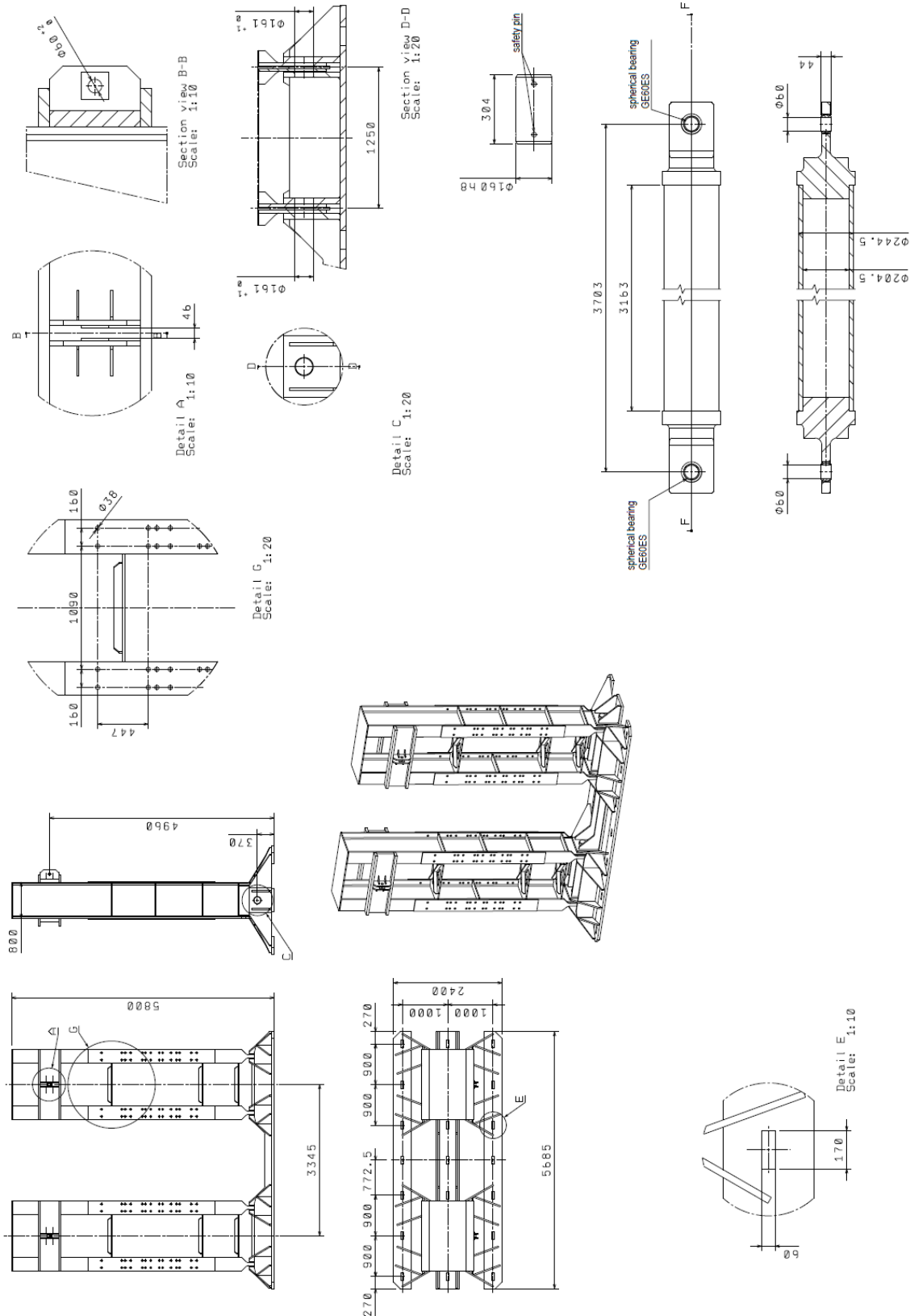



LOWA Rods Test Load Introduction System

ANNEX 2 – actuator's plates

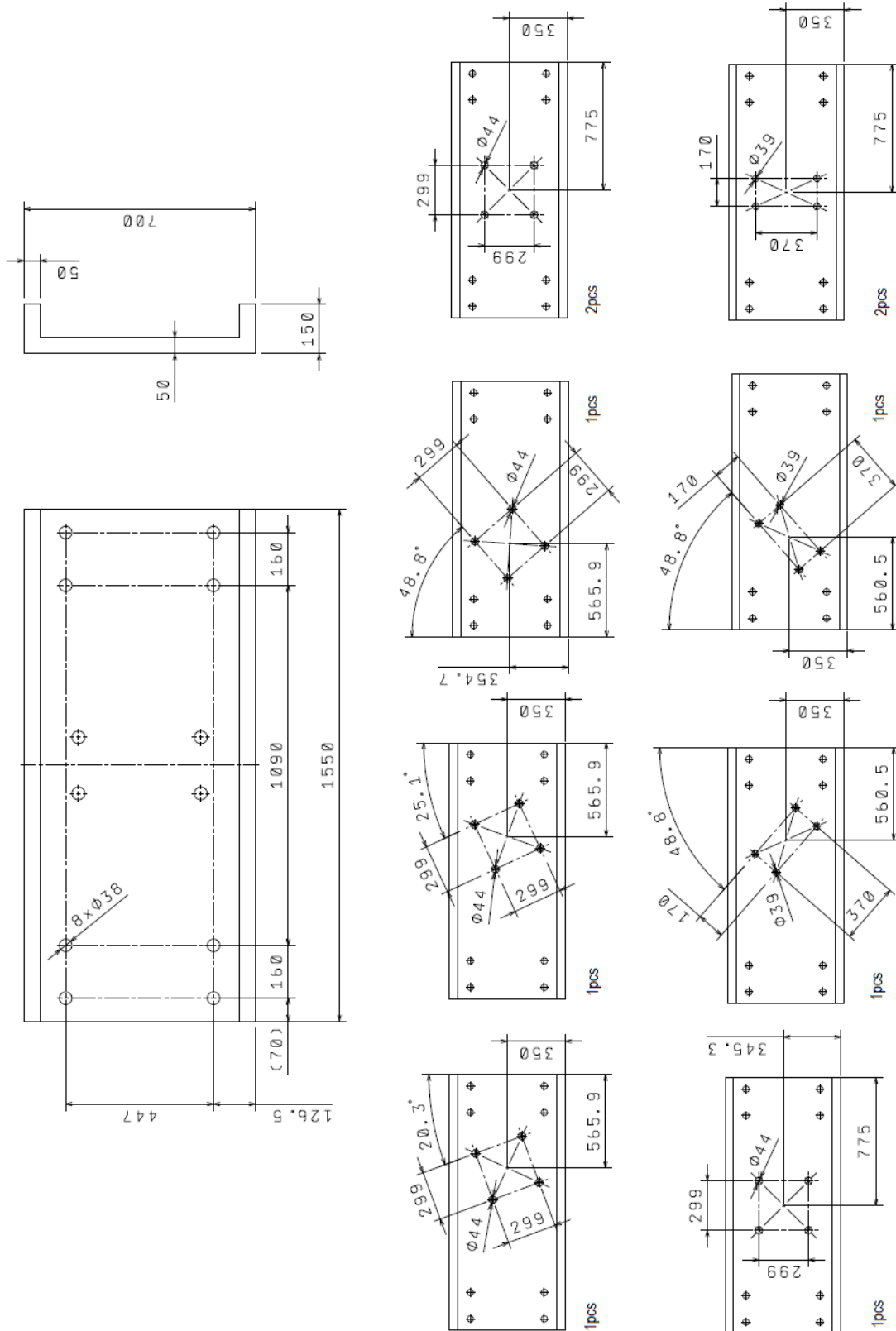

General tolerances according to ISO-2768-mK



Doc.No: **A6-TS-1530100-X-005-VZL**

Issue: **1.1** Date: **3.12.2020**

Page: **20** of **20**

LOWA Rods Test Load Introduction System

ANNEX 3 – 400 kN actuator's fitting

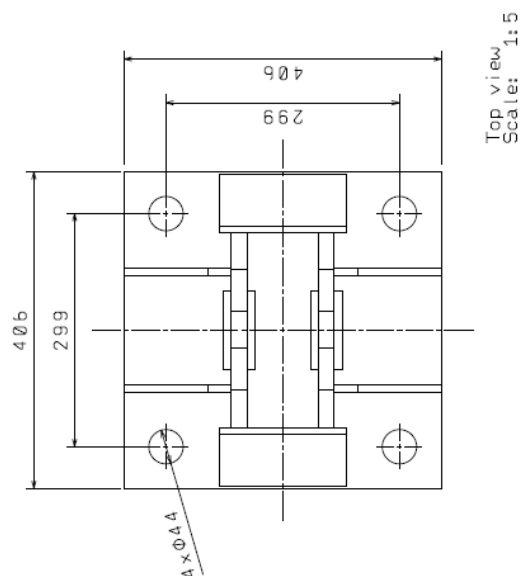
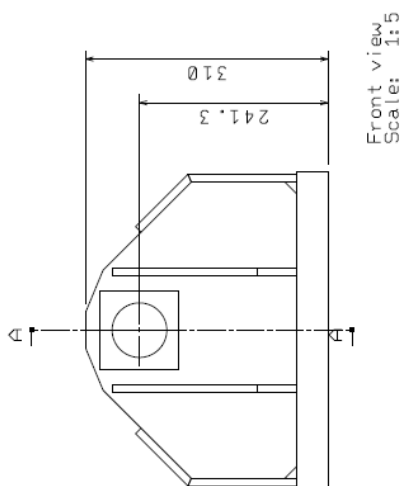
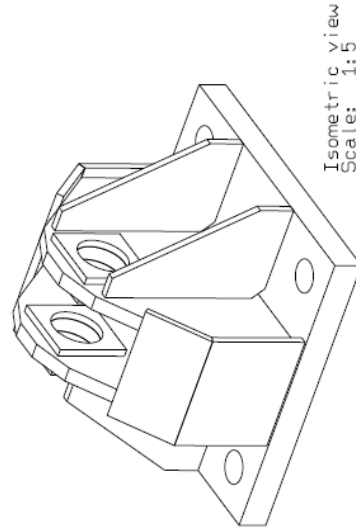
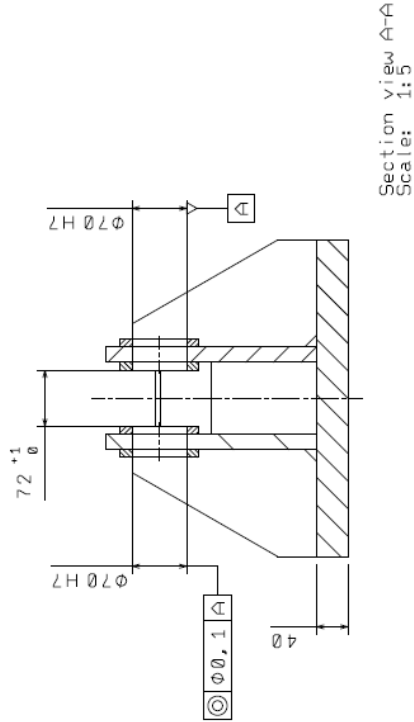

General tolerances according to ISO-2768-mK